

A wicker chair with a wooden frame sits on a rustic wooden deck. To the right, a potted orange tree with several ripe oranges stands in a red and white pot. In the foreground, a small green plate holds several round, golden-brown cookies, resting on a white cloth napkin. The scene is bathed in warm, natural light, creating a cozy outdoor atmosphere.

  
MADE IN  
GREAT BRITAIN

Live.  
Life.  
Outside.™

millboard®

# Bring your living room outside



# Discover

## the beauty of outdoor living

Because we believe that there is nothing as beautiful as the appearance of wood's natural grain, we've spent years perfecting an outdoor alternative that's just as attractive as the real thing, without the flaws of natural products.

Within these pages, you're invited to discover the Millboard collection in all its glory, from our stunning weathered creations that capture the character of hundred-year-old oak, to a contemporary burned-effect design, coastal-inspired looks and beyond.

Plus you'll also find outdoor inspiration to help you enjoy your space in style all year round.

**#LiveLifeOutside**



04

**WHAT IS  
MILLBOARD?**

The secret of our truly unique alternative to natural timber



06

**DESIGNED AND  
CRAFTED IN BRITAIN**

Discover the story and people behind Millboard craftsmanship



08

**THE MILLBOARD  
COLLECTION**

Introducing the complete collection of stunning finishes and colours



10

**MILLBOARD  
ENHANCED GRAIN**

Moulded from planed timber, for a subtly textured look and feel



14

**THE ART OF ESCAPISM**

Inspiring styling ideas for creating a space you'll want to linger in



16

**MILLBOARD  
WEATHERED OAK**

Moulded from 100-year-old weathered oak timber for a beautiful timeless look



20

**SECRET GARDEN**

How to create the perfect hideaway at home



22

**MILLBOARD  
CARBONISED**

The striking look of the traditional Japanese charred-wood technique



24

**DRAMATIC  
EFFECT**

Contemporary design touches for style-conscious spaces



26

**MILLBOARD  
LASTA-GRIP®**

Grip without the rip  
High anti-slip rating, perfect for commercial projects.



28

**MILLBOARD  
EDGING**

Complete the look with our selection of complementary edging



29

**MILLBOARD FASCIA**

Discreetly works with your choice of Millboard for a seamless look



34

**FIXTURES AND FITTINGS**

Essential additions to ensure the perfect fit and performance



40

**MILLBOARD ESTERNO**

For outdoor sophistication, style and reliability Esterno outdoor porcelain flooring is the perfect choice



46

**INSTALLATION GUIDE**

Tools and tips that you need for the perfect installation



58

**AFTERCARE AND HOW TO ORDER**

Get the most out of your Millboard installation with our handy tips on aftercare

# Come inside and rediscover outside...

08

**MILLBOARD COLLECTION**

36

**PLAS-PRO SUB FRAME**

38

**PEDESTALS AND SUPPORTS**

28

**EDGING**

32

**FASCIA**

35

**TOUCH UP COATING**

35

**DURAFIX FIXINGS GOING, GOING, GONE**

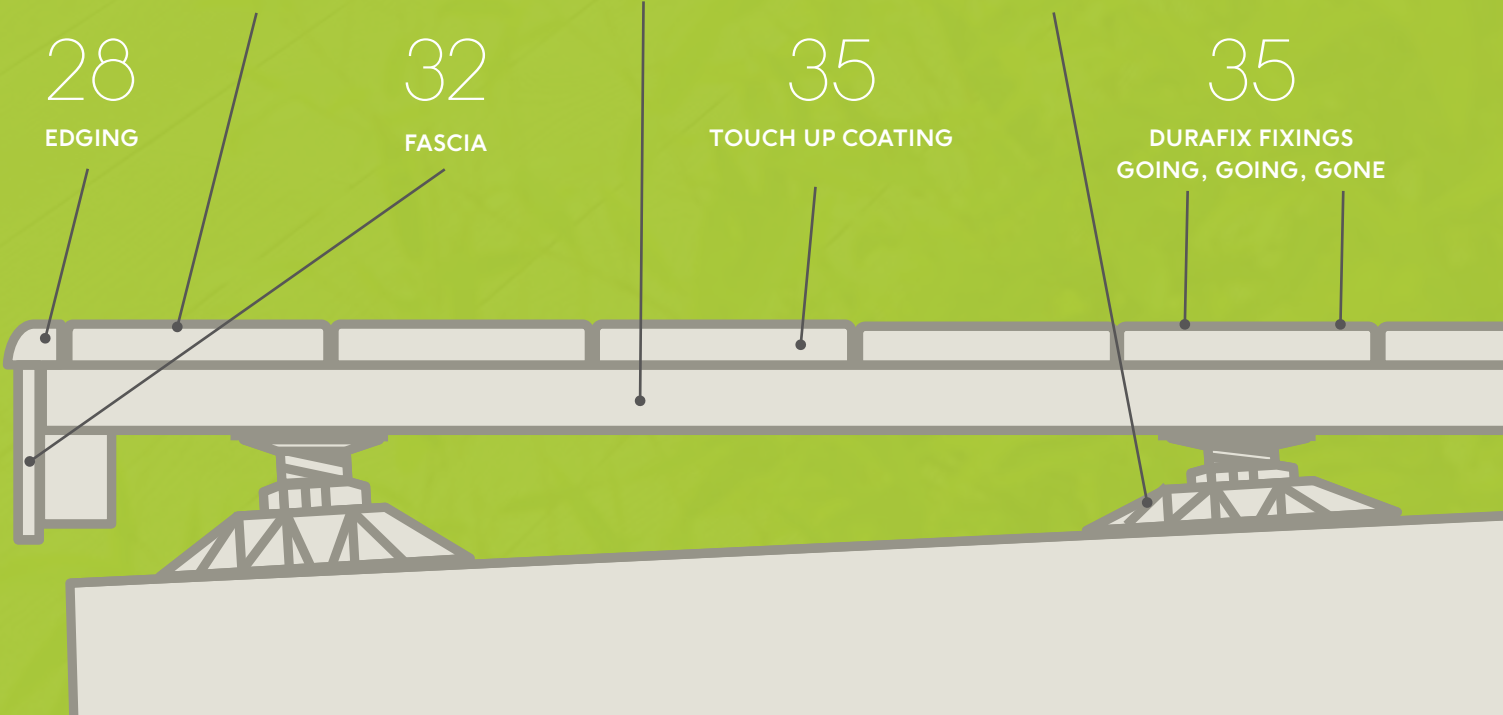

# What is Millboard?

**Millboard® combines the natural beauty of real timber with the high performance of our unique wood-free material.**



Where even the highest quality hardwood can warp, fade and quickly lose its original appeal over time, Millboard is crafted using a composite, designed for outdoor conditions. Made from Lastane®, the textured top surface creates a resilient, virtually maintenance-free layer, designed to resist algae and prevent slipping, even in wet conditions.

Beneath this durable top layer lies a wood-free polymer resin core, reinforced with fibre for extra strength and durability, which means that it won't expand or contract, warp or rot, like timber or composites made using wood. And because Millboard is made in Britain using innovative techniques, it's also eco-friendly too.



**Because we truly believe that British craftsmanship is amongst the world's finest, every Millboard is expertly designed and made by our team in Warwickshire.**



# Designed in Britain. Made in Britain.



The distinctive look of Millboard takes skill, impeccable attention to detail and patience to achieve.

The journey begins with real timber, which we source from the local area and carefully select by hand, paying particular attention to the subtle nuances of the natural grain. These timbers are then used to create the moulds for Millboard, enabling us to replicate the natural character of the original wood in our unique composite material.

Now our team of craftsmen can get to work transforming the raw Millboard into the designs for our collections.

To recreate the authentic look of hardwood, we carefully match the colour, using multiple tinted hues for depth and subtle variation, ageing and weathering. The beautiful, finished Millboard is just like the real thing, but made to last for years to come.



  
**MADE IN**  
GREAT BRITAIN



ISO 9001,  
ISO 14001,  
OHSAS 18001

Certificate Number 13959

# Millboard Enhanced Grain



# Millboard Carbonised



# Millboard Fascia and Edging



# Millboard Weathered Oak



Driftwood  
MDW200D



Vintage Oak  
MDW200V

## The Millboard Collection

# Millboard Lasta-Grip®



Coppered Oak  
MDL200C



Golden Oak  
MDL200G

# Plas-pro sub frame



Plas-pro post  
P1010B300



Plas-pro bearer / joist  
P1205B300



Plas-pro joist  
P0505240

Moulded from planed timber for a textured slip resistant look and feel, our Enhanced Grain collection recreates the subtle nuances that only natural wood can give. Each of the five shades showcases the grain beautifully.

# Millboard Enhanced Grain

Board size: 176 x 3600 x 32mm  
Available in five colours (see page 13)  
Colour shown above: Golden Oak



ULTRA-LOW  
MAINTENANCE  
REQUIRES MINIMAL  
UP KEEP







To find out more about the Millboard collection, including specifications, visit [www.millboard.co.uk](http://www.millboard.co.uk)



Coppered Oak

**COMPLETE THE LOOK**

SEE PAGE 29 FOR THE FINISHING TOUCHES TO MATCH YOUR MILLBOARD.

Take your pick from five authentic colours to suit your outdoor style.



Jarrah



Coppered Oak



Golden Oak



Smoked Oak



Limed Oak



DOES NOT ROT OR WARP LIKE TIMBER

# The art of escapism

Inspiring ideas for creating an outdoor retreat where you'll want to linger a little longer.

## ➔ Some like it hot

You needn't be naturally green-fingered, or go on holiday, to enjoy lush, year-round surrounds. Some tropical plant varieties are actually easier to take care of than our native British flora and fauna, and their striking, architectural leaves are high on impact. Look out for hardy palms, ferns and olives – great for withstanding harsh winters.



## ➔ When the sun goes down

Rather than retreating indoors after dark, transform your outdoor space into a light-filled, open-air room. Dot candles among shrubs, along the edge of Millboard spaces and walls to create atmosphere and ambiance. Old jam jars make a quick and quirky alternative to tealight holders.

## ⬅ Take inspiration from far-flung shores

With a few key accessories, any space can take on a new lease of life. Sculptural and architectural planting can create an atmospheric, exotic feel, and it's a look that's equally at home in large and small spaces.



Pin your millboard outdoor retreat





## A fresh twist on a childhood favourite

HOW TO MAKE THE PERFECT SUMMERTIME MINT LEMONADE



Homemade lemonade is the perfect crowd-pleaser and incredibly easy to make. Simply place a handful of fresh mint leaves into a tea towel and bruise with a rolling pin to release the zingy aroma. Pop it into a pitcher and squeeze in the juice of six lemons, plus a little zest, and add a good glug of sugarcane syrup. Top up with sparkling water, throw in plenty of ice and serve. Delicious.



Beautifully aged yet utterly timeless, our handcrafted Weathered Oak collection is moulded from 100-year-old reclaimed weathered oak timber, creating a distinctive worn look – without the wait.



# Millboard Weathered Oak

Board size: 200mm x 3600mm x 32mm  
Available in two colours: Vintage and Driftwood  
Colour shown above: Vintage



INTRICATE NATURAL  
WOODGRAIN DETAIL



Millboard Weathered Oak Driftwood

 **Create your own natural wonder**

The Millboard Weathered Oak collection's soft, lived-in feel is the perfect partner for other natural materials. Think stone and driftwood accessories and coastal-inspired painted timber.



**RESISTS TO FOOD  
& DRINK STAINS**

**Weathered Oak  
colours available:**



Driftwood



Vintage

TO FIND OUT MORE ABOUT THE  
MILLBOARD COLLECTION,  
INCLUDING SPECIFICATIONS,  
GO TO [WWW.MILLBOARD.CO.UK](http://WWW.MILLBOARD.CO.UK)





#dogsondecks



Millboard Weathered Oak Driftwood

# Secret garden

Discover more ways to enjoy your outdoor space with tucked-away corners hidden behind lush plants and imaginative finishing touches.



## GET THE LOOK Perfect hideaway

MILLBOARD MAKES PUTTING YOUR PERSONAL STAMP ONTO ANY SPACE SIMPLE.

If your garden or patio is a single rectangular area, add character by creating smaller zones, and experiment with raised areas for a more interesting flow. Plant-filled dividers enable you to play with scale and break up a larger area into 'rooms', creating a versatile outdoor space adaptable for different uses and moods.

### ⬇ Mix it up with eclectic accessories

Handcrafted pieces such as this unusual stool, carved from a tree trunk, add personality and a dash of well-travelled chic.



### ⬅ Reflect your personal style

A shabby-chic mirror dressed with delicate fairy lights makes an eye-catching feature, day or night, and is a simple trick for adding a sense of light and space to smaller areas. Why not trail with climbing plants for a pretty alternative to a trellis?





Share your millboard pictures on  
[facebook.com/MillboardFlooring](https://facebook.com/MillboardFlooring)



Millboard Carbonised Embered with Esterno Capital Graphite

Inspired by the traditional Japanese Shou Sugi Ban technique, where timber's surface is burned to create a striking and long-lasting finish, our Carbonised collection combines practicality with raw beauty. Choose from a planed, charred look or dramatic embered effect.

# Millboard Carbonised

Embered Board size: 200 x 3600 x 32mm  
Charred Board size: 176 x 3600 x 32mm  
Colour shown above: Embered



HIGHLY RESISTANT  
TO ALGAE GROWTH



Millboard Carbonised Charred  
with Smoked Oak



 **Clean lines and monochrome**

Millboard Carbonised is the perfect partner for contemporary outdoor spaces. Mix and match rough and smooth textures, matt and glossy, light and dark, for an on-trend edge.

Choose from two distinctive finishes to suit your style and space.

Embered (200 x 3600 x 32mm)



Charred (176 x 3600 x 32mm)

Millboard Carbonised Charred



Floor: Millboard Enhanced Grain Limed Oak. Wall: Carbonised Charred



**Bring the indoors out**

Glossy metal furniture makes a sleek alternative to traditional natural materials. Choose sculptural, modernist pieces, such as the iconic Eames design, and go for chrome, black or white designs that show off the silhouette.

# Dramatic effect

Create an outdoor space as style-conscious and contemporary as the rest of your home, with bold design details and on-trend finishing touches.

## GET THE LOOK New heights

THE MILLBOARD COLLECTION'S VERSATILITY MEANS THAT, WHEN IT COMES TO CREATIVITY, THE SKY'S THE LIMIT.

Why stop the fun at your floor space? Create an urban oasis with a Millboard-lined, plant-filled statement wall, or keep it chic and simple by using different colours and textures to create zones within larger spaces. Continuing the same Millboard style up terrace walls gives the illusion of more space.



### In perfect balance

A cool, monochrome palette creates the perfect backdrop for playful lighting. Continue the Japanese-inspired theme of the Millboard Carbonised collection with paper lanterns, or inject a shot of colour with a delicate garland.



MILLBOARD IS HIGHLY UV STABLE. SO OVERTIME CHANGES IN TONE ARE MINIMAL



### ➔ Grip without the rip

Because you never know what the weather may bring, Millboard Lasta-Grip® is prepared for every eventuality. The moulded, multi-strip surface texture and Lastane® coating work together to prevent shoes slipping, even when wet, meaning that you can use and enjoy your outdoor space without any fear of slip-ups. The design also reduces any noise from moving furniture, making it the perfect choice for alfresco dining areas.



Golden Oak (200 x 3600 x 32mm)



Coppered Oak (200 x 3600 x 32mm)



**Our Lasta-Grip® collection's textured design offers a high anti-slip rating without the rough feel of other gritted strip boards.**

**Perfect for public spaces, by the pool, play areas and anywhere there's rain or water.**

# Millboard Lasta-Grip®

Board size: 200 x 3600 x 32mm



ALMOST INVISIBLE  
DURAFIX® 'LOST HEAD' FIXING

# Millboard Edging

## New Square Edging

Size: 50 x 3200 x 33mm (Standard)



Millboard Coppered Oak with Square Edging

TO FIND OUT MORE ABOUT THE MILLBOARD COLLECTION, INCLUDING SPECIFICATIONS, GO TO [WWW.MILLBOARD.CO.UK](http://WWW.MILLBOARD.CO.UK)

Complete the Millboard look with our Edging collection. It's the perfect finishing touch, designed to minimise wear and available in two designs, seven colours and either standard or flexible and standard for bullnose.

# Bullnose Edging

Size: 50 x 3200 x 33mm (Standard) / 50 x 2400 x 33mm (Flexible)



Millboard Golden Oak with Bullnose Edging

Live.  
Life.  
Outside.™







Jarrah - MFN320J



Carbonised - MFN320E





Coppered Oak - MFN320C

# Millboard Fascia

Fascia size: 146 x 3200 x 16mm

**Because the finer details matter, our Fascia collection discreetly works with your choice of Millboard, ensuring the final look is seamless.**



Limed Oak - MFN320L



Smoked Oak/Driftwood - MFN320D

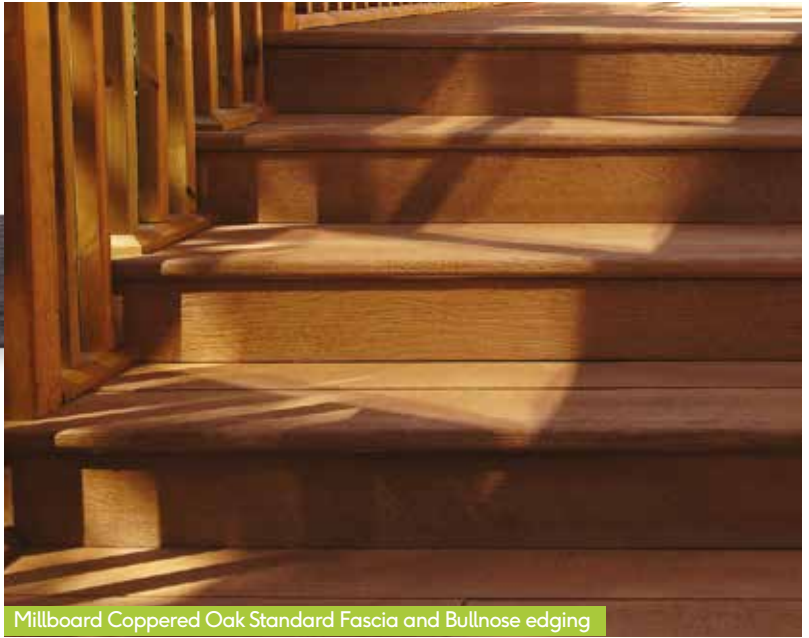

Millboard Coppered Oak Standard Fascia and Bullnose edging

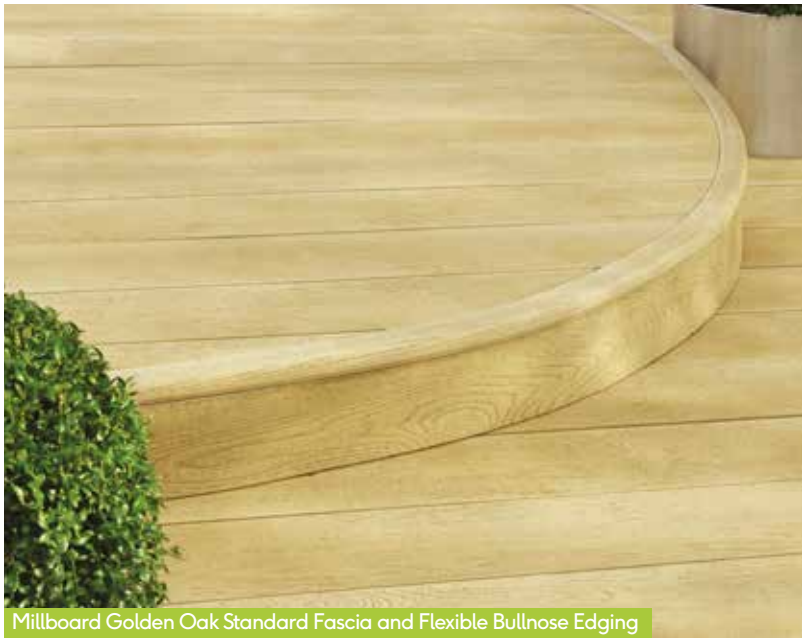

Millboard Golden Oak Standard Fascia and Flexible Bullnose Edging



# Fixtures and fittings

Essential additions to ensure the perfect fit and performance.

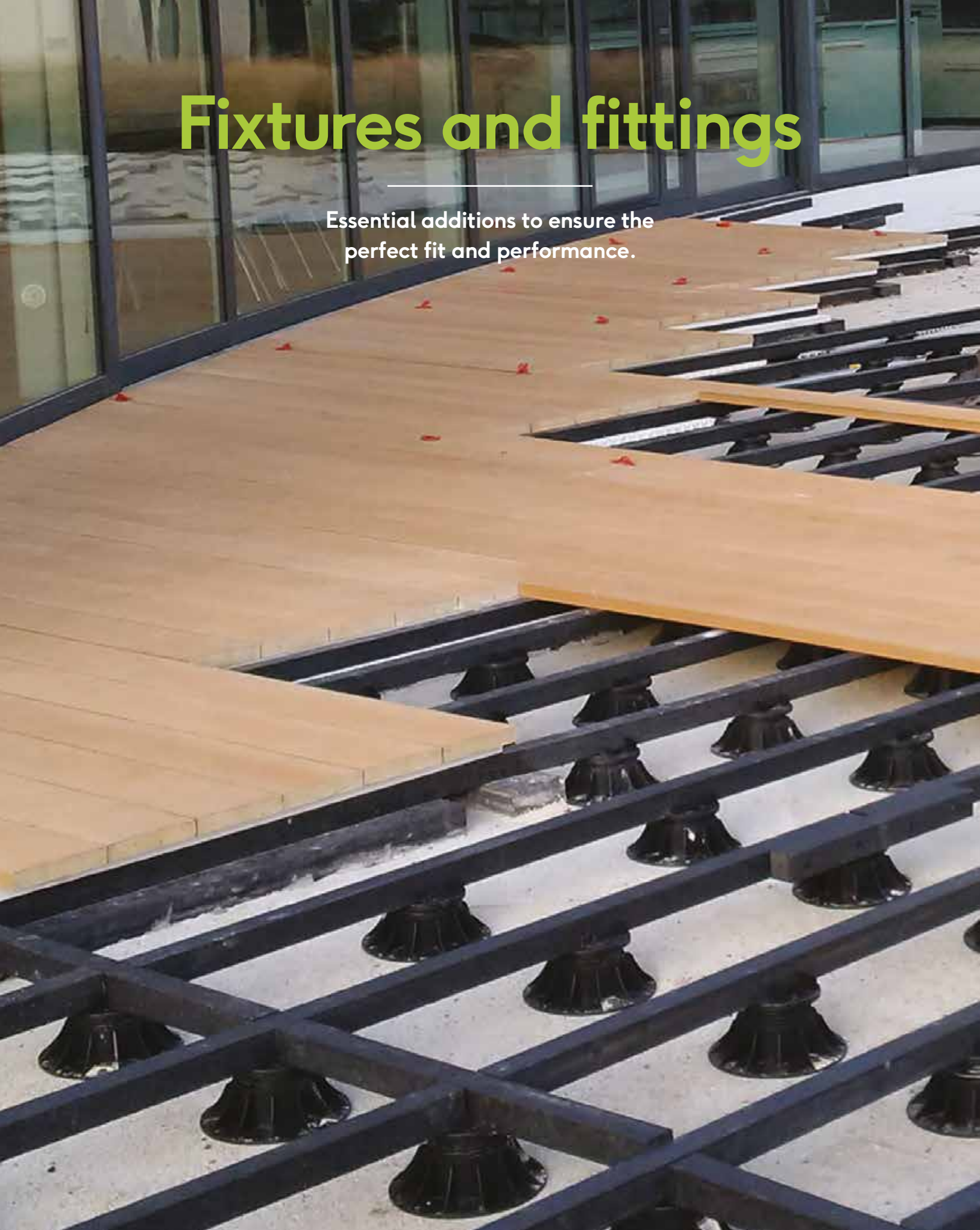

# Touch-up coating

Perfect for blending in exposed cut ends, our touch-up coatings are available in a range of seven colours to match your Millboard.

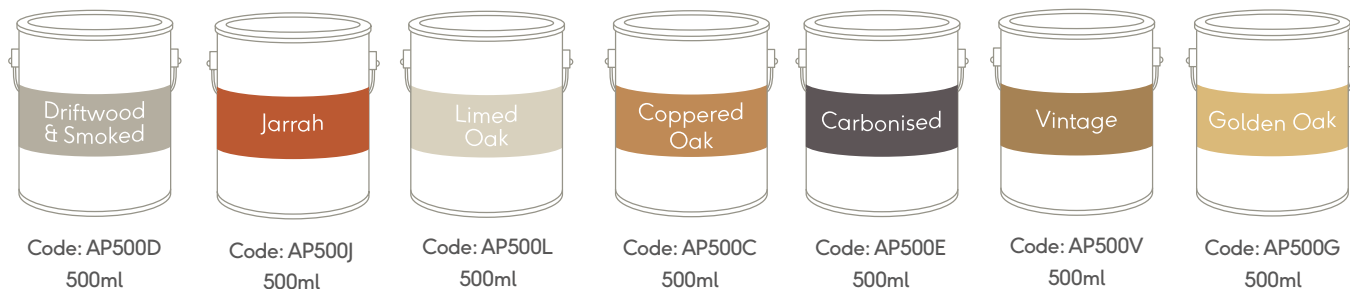

# Going, Going, Gone...

Our unique Durafix®, hidden decking fixings make installing Millboard simple. There's no pre-drilling, counter sinking or clip fixings needed – all you need to do is screw them in. Once they're in, the Lastane® coating material on every Millboard simply flexes back over the fixing, leaving a virtually indistinguishable mark and creating a cleaner finish. Made from stainless steel, the screws have a six-point Torx head and are waxed for ease of use. And the driver bits are even included in the box.



## Durafix® fixings

### Fixings

|            |            |                |
|------------|------------|----------------|
| 4.5 x 50mm | Box of 250 | Code: FT50P250 |
| 4.5 x 60mm | Box of 250 | Code: FT60P250 |



# Plas-pro solutions

The ideal companion for our all-weather flooring, and a durable, hardwearing and practical solution for spaces exposed to damp, such as jetties, fishing platforms, pools, roof terraces and boardwalks. Made from 100% recycled plastic, it won't rot, split or crack like wood.



## What is Plas-pro?

Plas-Pro is made from 100% recycled plastic. Using selected graded materials and cleverly engineered processes, Plas-Pro not only brings the key environmental benefits, but the assurance of superior quality performance.

Being impervious to water ingress Plas-pro will not rot, swell or split like wood, making it particularly suitable around water and damp environments such as jetties, fishing platforms, roof terraces and boardwalks ensuring a maintenance-free solution.

## Why Plas-pro?

Plas-Pro offers many longer term advantages above traditional construction materials such as timber. Designed for the discerning specifier and client looking for durable and cost effective lasting solutions.

Plas-Pro complements our terrace pedestal products and the unique Millboard outdoor flooring range, enabling us to offer a complete, full turn-key, non-rot outdoor flooring system.

100 x 100 x 3000mm - Plas-pro post - P1010B300

125 x 50 x 3000mm - Plas-pro joist - P1205B300

50 x 50 x 2400mm - Plas-pro bearer - P0505240

# Outdoor flooring system

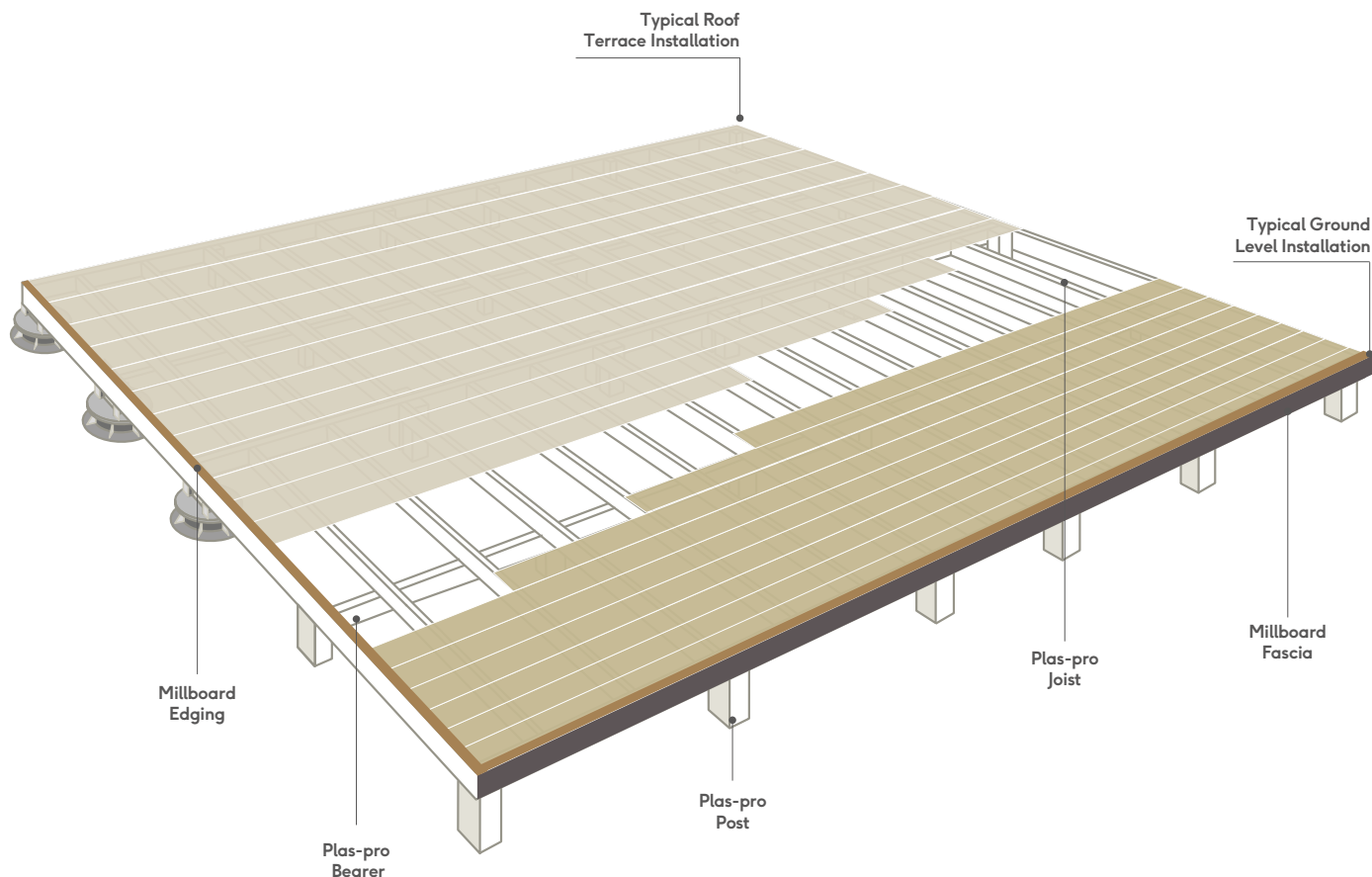

## Subframe hexhead screw

Our subframe screw fixings make installing Millboard Plas-pro subframes simple. With just a pre-drilled hole required, these heavy duty coated hex flange head screws have a type 17 'gash' point to reduce drive torque. These fixings are also suitable for timber subframe systems



### Fixings

6.3 x 90mm

Box of 50

Code: FH90P050

# Pedestals

Our adjustable self-levelling pedestals are ideal for podium decks and terraces. The unique 'Self-levelling' head ensures easier, faster and more stable installations. Their smart design allows pipe work and services to be laid beneath Millboard, while also improving breathability and reducing rot which can occur to roof timbers or a timber sub structure. The weight of the joist is spread evenly, creating a sturdy support, and reducing pressure on the membrane. They're available in incremental adjustable sizes, from 40-300mm giving you complete control of the height of the area.

## Number per m<sup>2</sup>\*

|             |     |
|-------------|-----|
| Residential | 5.0 |
| Commercial  | 8.0 |

\* Approx number - quantities may vary according to project design



## Adjustable joist cradle

Our plastic joist cradles are the ideal foundation when installing on roof terraces or over patios. The joist cradles also have an acoustic benefit to help reduce sound transfer. Quick and easy to install their height is adjustable from 10-40mm.

### Number per m<sup>2</sup>\*

|             |     |
|-------------|-----|
| Residential | 5.0 |
|-------------|-----|

|            |     |
|------------|-----|
| Commercial | 8.0 |
|------------|-----|

\* Approx number - quantities may vary according to project design

|                         |            |
|-------------------------|------------|
| Adjustable Joist Cradle | Code: PJ40 |
|-------------------------|------------|

## Ring supports

Millboard ring supports are designed for use in low height areas, creating airflow and protecting the roof membrane, while allowing water to flow off easily and prevent pooling.

| Number per m <sup>2</sup> * | millboard | Esterno(600x600mm) | Esterno(900x450mm) |
|-----------------------------|-----------|--------------------|--------------------|
| Residential                 | 5.0       | 3.25               | 6.0                |
| Commercial                  | 8.0       | 6.0                | 6.0                |

\* Approx number - quantities may vary according to project design

|                 |             |
|-----------------|-------------|
| Rubber ring 9mm | Code: PPR09 |
|-----------------|-------------|

|                   |             |
|-------------------|-------------|
| Plastic ring 15mm | Code: PPR15 |
|-------------------|-------------|

|                           |             |
|---------------------------|-------------|
| 3mm spacers for 15mm ring | Code: PPR03 |
|---------------------------|-------------|





**From Millboard® to Esterno®**  
Outdoor porcelain flooring

# Six good reasons for Esterno<sup>®</sup> outdoor porcelain flooring

To compliment the Millboard range when creating zoned areas, Millboard offers the Esterno outdoor porcelain flooring range.

Esterno's low porosity surface resists stains and algae growth. The easier to clean surface ensures more time enjoying your outdoor space and less time maintaining it. For outdoor sophistication, style and reliability Esterno outdoor porcelain flooring is the perfect choice. Esterno is a consistent single material blend porcelain stoneware tile. It is frost resistant, perfectly squared and rectified with 20mm thickness.



**Low slip in the wet (R10-R11)**



**Frost Resistant**



**Scratch Resistant**



**Low Maintenance**



**Quick and easy installation**



**Bare foot friendly**

# Esterno Collection



**Esterno  
Capital**

The Capital collection offers a smoother, soft riven surface in a rectangular design in two striking colour variants.



**Graphite  
ENT49GE**

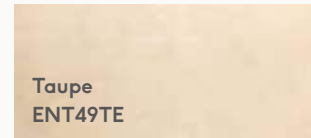

**Taupe  
ENT49TE**

Inspired by flamed limestone, the Earth Stone range truly replicates a contemporary style and finish.



**Sand  
ENT66ND**

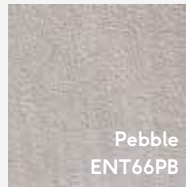

**Pebble  
ENT66PB**



**Pumice  
ENT66PM**



**Esterno  
Earth Stone**



**Esterno  
Elements**

The Elements range brings to life the timeless rustic beauty of quartz, in any project.

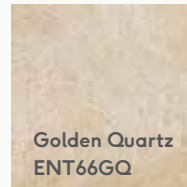

**Golden Quartz  
ENT66GQ**

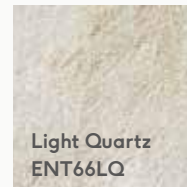

**Light Quartz  
ENT66LQ**

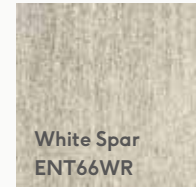

**White Spar  
ENT66WR**

The Urban flooring brings style and sophistication to your project with a clean and contemporary palette.

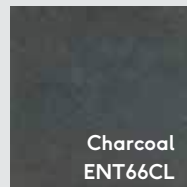

**Charcoal  
ENT66CL**



**Esterno  
Urban**



**Esterno  
Metropolis**

The clean design of the Metropolis flooring brings the minimalistic effect of timber shuttered concrete.

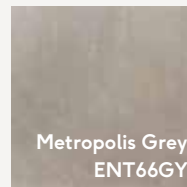

**Metropolis Grey  
ENT66GY**



## Esterno Processes

Due to manufacturing processes and natural materials used, there may be varying degrees of shade variations as described below and indicated on these swatches.

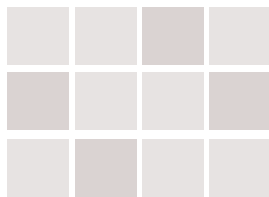

V2 (Esterno Capital, Earth Stone, Urban, Metropolis)  
**Minimum Variation**  
Visible variations but similar shades

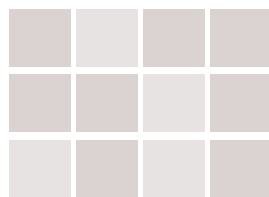

V3 (Elements)  
**Moderate Variation**  
Significant shade variations

# Installation onto grass

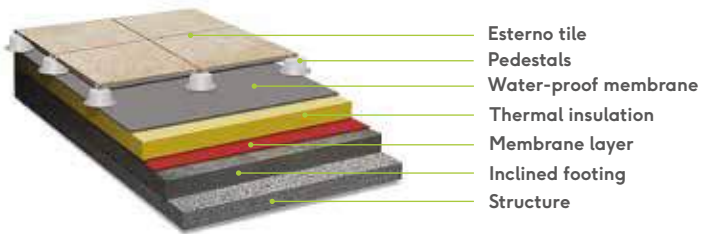
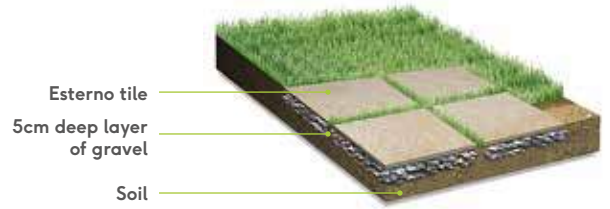

# Raised Installation

# Traditional Adhesive Installation

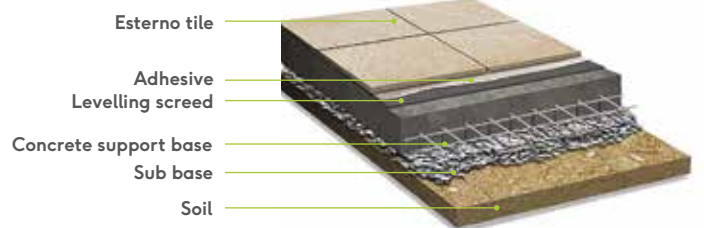



Esterno Elements Light Quartz

## Esterno V spacer

Our Esterno V spacer makes installing Esterno outdoor porcelain flooring simple for pedestal system installations adjacent to walls.

The Esterno V spacer assists drainage and creates an airflow gap between surfaces. With a minimum of two V spacers per tile edge, simply place the V spacer in between the wall and Esterno tile to hold the tile away from the wall, until the bonding of the tile to the pedestal has set.



### Fixings

33 x 25mm

Box of 100

Code: EAV33

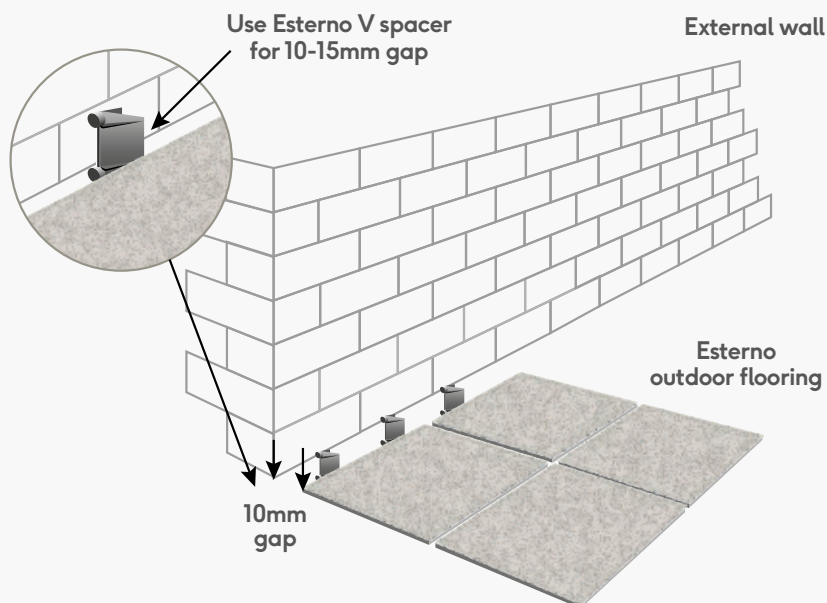

# Installation and User Guide





# Tools

---

**These are the tools that you need to install Millboard.**



**Circular saw/jigsaw**



**Dustmask, gloves and safety glasses**



**Handsaw**



**String line**



**Power drill and driver**



**Spirit level**



**Tape measure**



**Set Square**





# Millboard Installation and User Guide

## Storage and handling

Millboard should always be stored on a flat surface or level bearers a maximum of 400mm apart and stacked face-to-face, not back-to-face. Be careful not to drag the Millboard off the pallet or over each other, as this could cause abrasion or marking on the surface and only move the pallet if the Millboard is safely strapped to it. Wear gloves and long sleeves when handling Millboard and take care when lifting the boards—as Millboard is solid rather than hollow. We recommend that two people carry the boards.

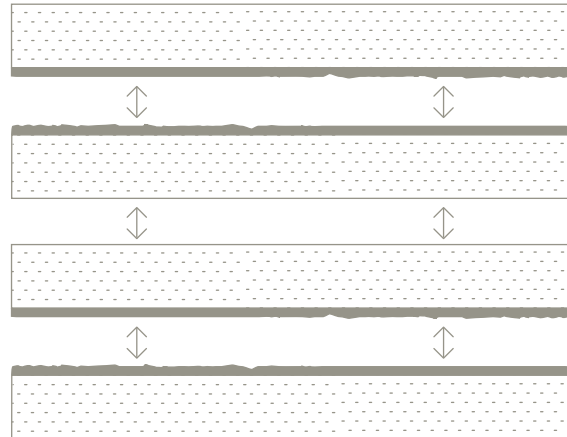

Boards should be stacked face-to-face

## Colour

To recreate the aesthetics of natural products, we intentionally add secondary toning colours. There may be variance within the same board or from board to board in colour tone. This means that samples cut from boards may vary from the general colour of the boarding.

With our range of colours, you can choose what is best for you. As with all products, the darker colours will feel warmer in sunny exposed locations. The lighter colours are normally used in such locations.

Whilst every care is taken to ensure consistency some colour variation from batch to batch may occur. To avoid this, we recommend that you order all you need in one delivery. If you do have different batches it is best to mix the batches to blend the colours. As with all things constantly exposed to ultra violet light and all weathers, colours will tone slightly in time, this is normal for decking. On delivery if you find the colour unacceptable or believe them to be defective in any way, do not install the boards.



Colour tone may vary from batch to batch



## Joist spacing

Joist spacing of 400mm between joist centres is recommended for normal residential and light commercial use ①. On heavy commercial, bridges, balconies, moorings, doorways and steps, use 300mm between joist centres. If you need to cut Millboard down along the length, then reduce the joist centres accordingly. A minimum of three joists is required for any cut boards.

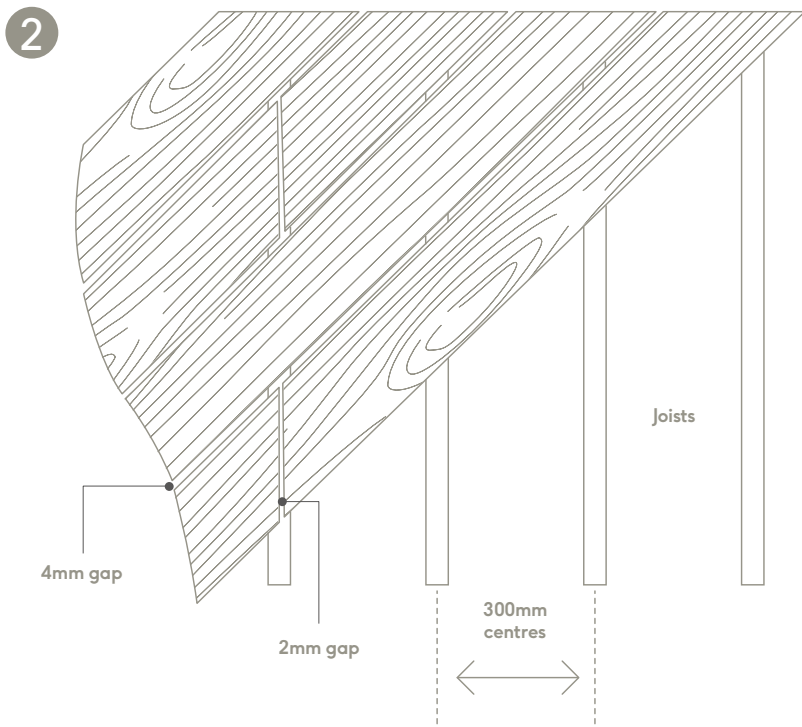
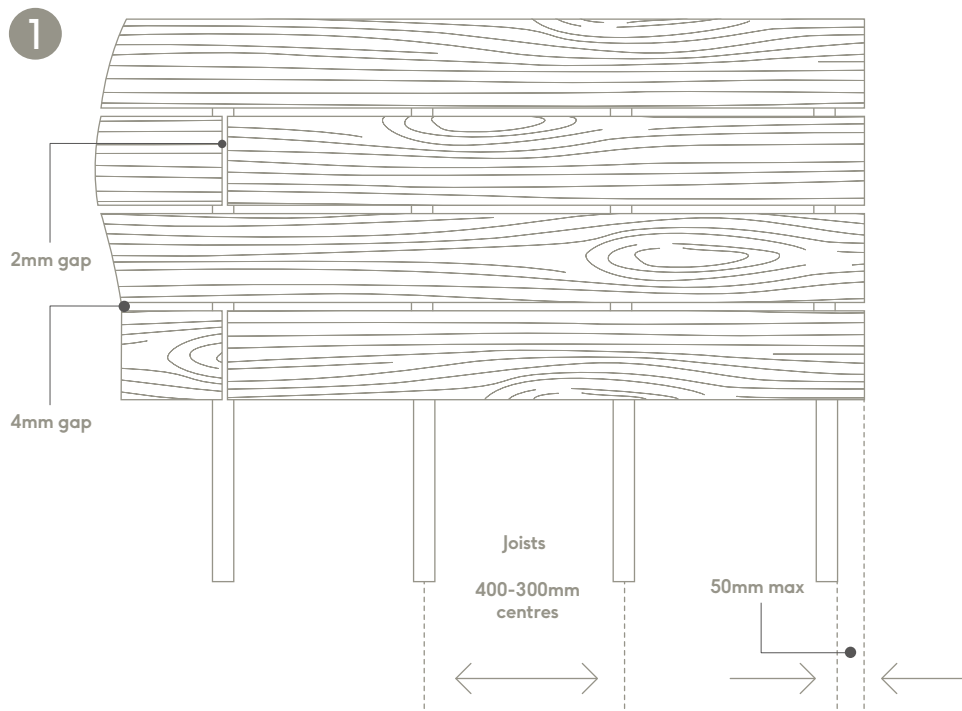

② For laying 45° to the joist, reduce the joist centres to 300mm for residential and 240mm for commercial use.

Always leave a 10mm expansion gap between ends of bearers and joists.

To install Plas-Pro frame solutions, drill the fixing holes oversize to allow the material to expand. Posts should always have a minimum of a third of their length in the ground, subject to a minimum of 400mm in the ground. Joist ends must always be positioned over bearers.



# Millboard Installation and User Guide

## Fastening to substructure

Millboard Durafix® stainless steel fixings mean that there's no need to pre-drill or countersink, just screw straight in. When fixing in, push down, start the driver slowly and speed up; then slow down when driving the head of the screw through the Lastane® ③. Stop the screw about 5mm below the surface ④. This should leave a small, virtually indistinguishable hole. Failure to use our Durafix® Fixings or not fitting according to these guidelines may invalidate the warranty.

Two fixings per board should be used where the board crosses a joist, we advise to use three at the ends of the boards on shorter lengths. The fixings at the ends of the boards should be fixed at a slight angle to prevent being too close to the end of the board ⑤, positioning the screws 20-25mm from the ends and 30mm from the sides of the boards. Board ends should be supported by a minimum of 20mm. As the boards are dimensionally stable, they can be fitted with only 4mm spacing and 2mm gap at the ends of the boards. Cuts must always be positioned over the joist. Boards may have a +/- 2% dimensional variance. Best practice is to fix the boards at one end, then a fixing in the middle adjusting spacing as necessary, then the far end. Then fix to the remaining joists. We recommend working to a string line.

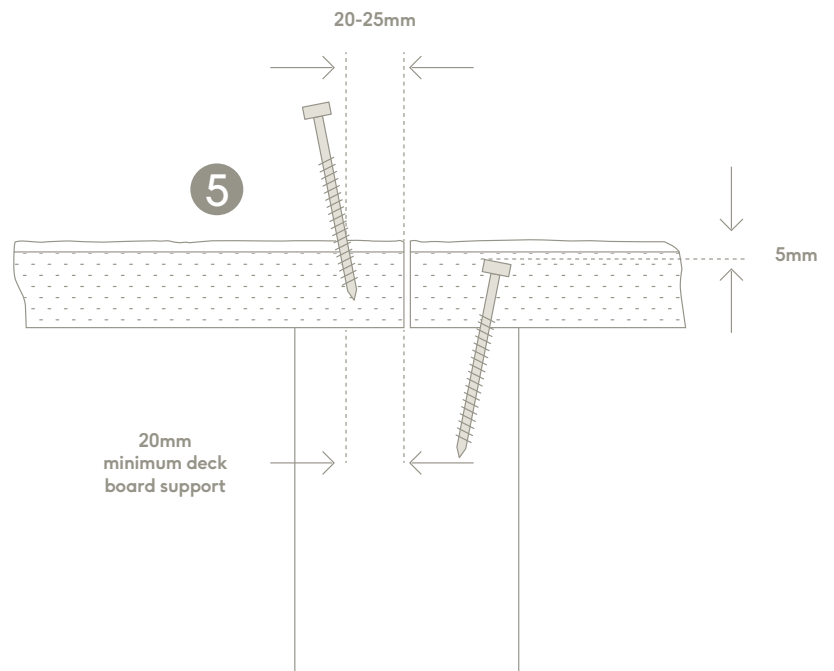
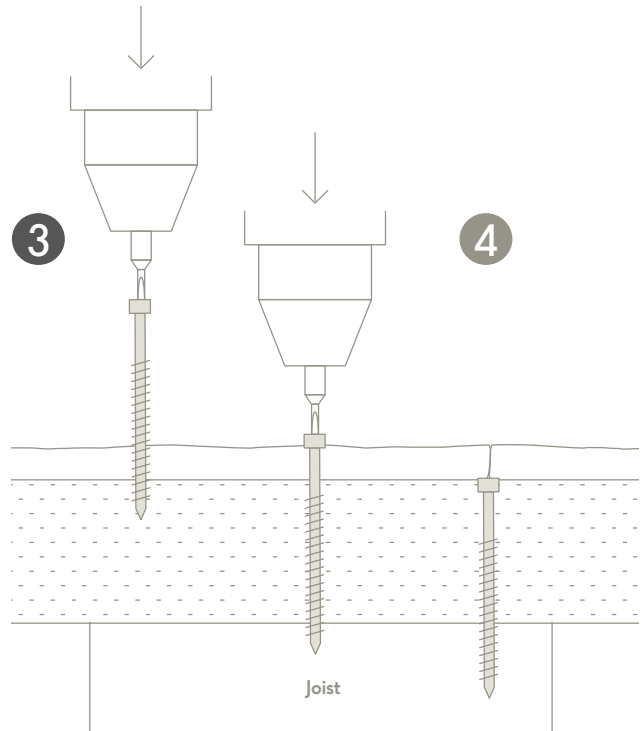

## Cutting the Millboard

Millboard can be cut with standard saw blades, although we recommend a carbon-tipped, multi-purpose chop saw. As the formed end of the Millboard is lost when cut, these can be placed in less visual areas against a wall or edging profile. Use our Edgings (page 28) or Touch-up coating (page 35) where they are visible. Dispose of off-cuts as general waste, don't burn them. When cutting the Millboard, wear a dust mask, safety glasses, long sleeves and protective gloves. A dust bag must be used on chop saws. Make sure that the Millboard is adequately supported when cutting.

## Fascia boards, steps and edges

We recommend that our purpose-made edging be fitted to all steps and perimeters of the deck. It's coated with extra Lastane® for added resilience on these areas, helping prevent excessive wear. Edging is available in either a Bullnose **6** or Square profile **7**. Ensure that the edging is supported on a joist by a minimum of 25mm. We recommend trimming the ends to butt tightly when fitting both edging and fascias. For the best visual effect, stagger the edging and fascia joints so that they're not in line – this creates a subtler look.

We also manufacture the Bullnose edging in a flexible material suitable for curved designs. Flexible Bullnose edgings can be curved to follow a maximum convex diameter of 2.4metres. These flexible profiles need to be at least room temperature (c.20°C), then bent gently. Standard fascia will bend up to 2.4m convex diameter. When fixing start from the end and work along, fixing at 300mm intervals as you go. This flexible material doesn't conceal the fixings as well, leaving some holes partially visible.



## Taking care

If the Millboard picks up marks during installation simply wash with hot, soapy water and a firm broom straightaway. To remove any cement and lime-based stains, we recommend using Geocel Brick & Mortar Cleaner. Test a small area first and follow the mixing instructions, leaving for five minutes before washing off with soapy water.

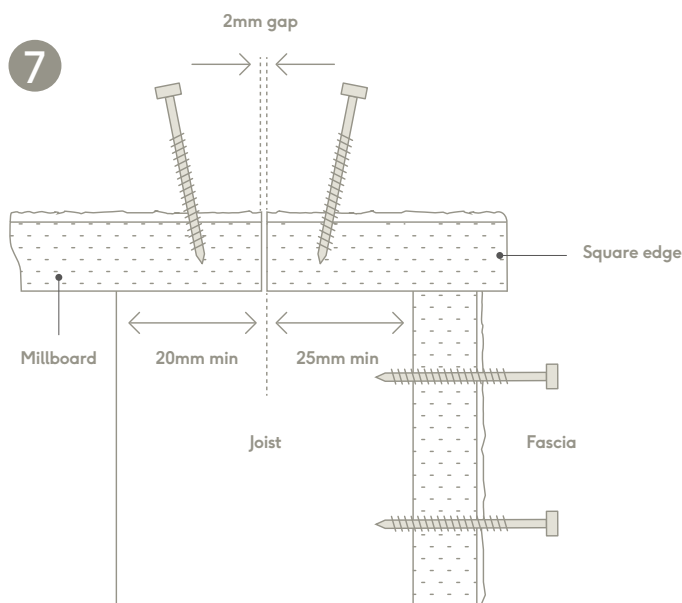
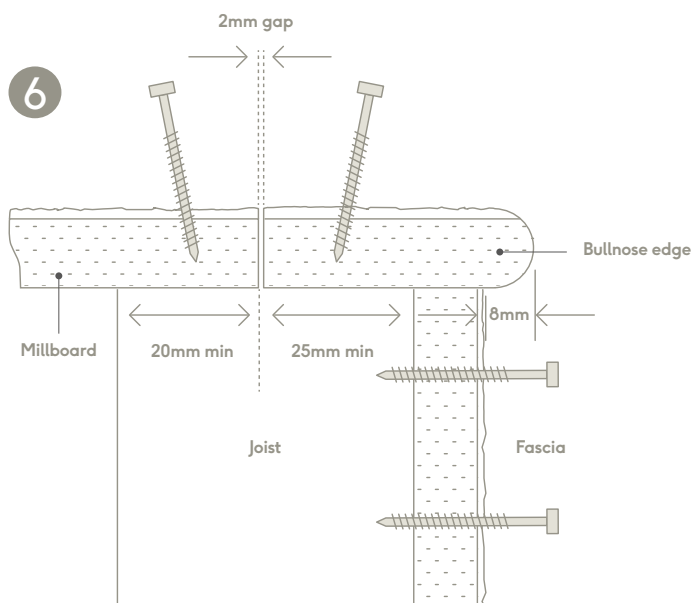

# Esterno® Installation

The dry installation system does not require the use of tile adhesives or grouts. The system is therefore easy to install and remove and does not require acid cleaning after installation. The substrate onto which the supports are to be installed, must be solid, water resistant or waterproof; equipped with four spacers to allow adequate joints between adjacent tiles. Use the Esterno V spacer against walls/borders to prevent lateral movement. Simply remove the plastic lugs from the top of the pedestal to create a flat support. We recommend to bond the outer two rows of tiles to the pedestals with a MS polymer adhesive.

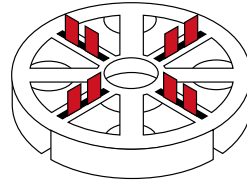

The lugs shown in red can be easily removed to form the desired support orientation.

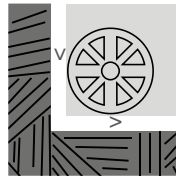

Wall corner

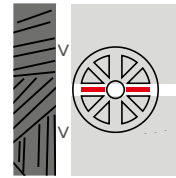

Wall border

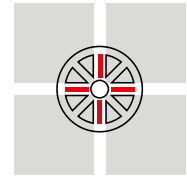

Centre

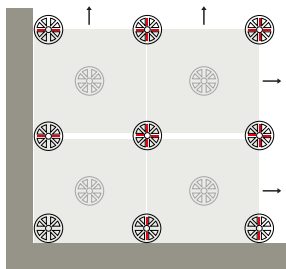

600 x 600mm

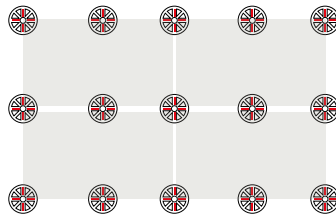

900 x 450mm

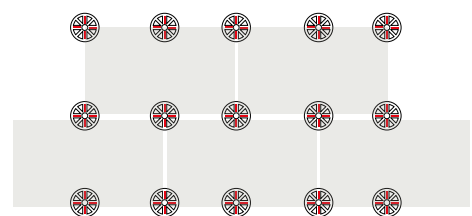

900 x 450mm



## Ring Supports

Esterno polypropylene supports are suitable for the installation of Esterno panels to varying heights. The 15mm plastic disc is stackable to allow for increased height and can also incorporate 3mm packer for finer adjustment.

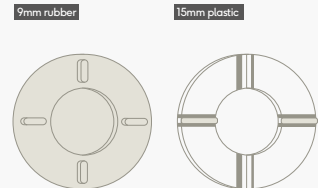

## Adjustable Self-Levelling Pedestals

For structures requiring adjustable heights from 40 to 300mm.

The adjustable element on the head of the support can be easily reached from above allowing for the correct setting of the height when fixing, without removing the tiles.

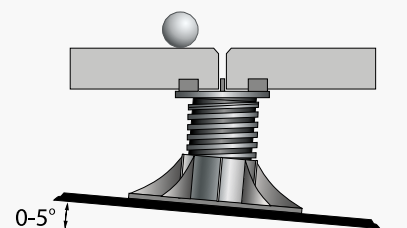



## Edging, steps and drainage

Edging, steps and drainage are made to order, so please allow 4-6 weeks delivery

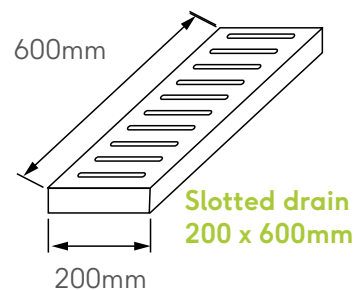
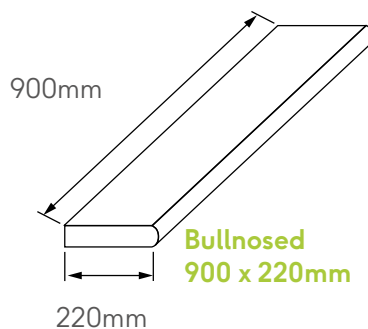
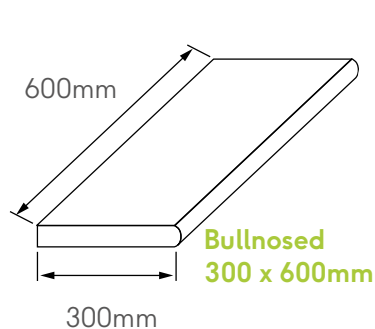

# Frequently asked questions

## Where can I use Millboard?

Millboard is extremely versatile and can be used in practically every outdoor space. Create decks, balconies, roof gardens, boardwalks, bridges, pontoons, seating, steps, planters and more.

## Do I need to seal Millboard?

No, all Millboards are surface sealed in the factory to ensure they arrive in premium condition. In the first few weeks of use, rainwater will sit on the surface in globules, but don't worry – this is normal and will stop once the temporary surface seal breaks down.

## Does Millboard mark?

The Lastane® finish is highly resistant to scratches and food and drink stains, and everyday wear and tear. Sharp objects such as unprotected table or chair legs, spiked shoes or metal planter bases can leave marks if dragged across the surface, so take care when moving these items around. The risk of marking from strong dyes and stains such as berries and animal droppings will be reduced if removed as soon as possible.

## How do I clean Millboard?

Because Millboard is made of non-porous composite, it resists mossy build-up and stains, so needs very little maintenance. To remove spills and marks, simply use a mild detergent and a cloth. Just steer clear of solvents, chemicals and abrasive cleaners that could damage your Millboard – and there's normally no need for pressure washing.

## What if it snows or is icy?

A small amount of granulated white salt can be used to keep your Millboard ice-free. Please don't use rock salt, as this contains clay and grit and can be abrasive. When winter's over, clean the surface with soapy water and a soft broom.

## Does Millboard come with a Warranty?

For more information go to [www.millboard.co.uk/warranty](http://www.millboard.co.uk/warranty)

## Is Millboard anti-slip?

Yes, in BS79.76 slip resistance tests, all styles of Millboard achieve one of the highest anti-slip ratings, even in wet conditions.

## Are Millboard colours consistent?

As with all flooring, we advise buying all the Millboard you need at the same time to help ensure that the colour is as consistent as possible. If you don't order all your Millboard at once, you can blend different batches to create only subtle variation throughout your space.

## Can Millboard be cut just like wood?

Millboard can be cut with standard saw blades, although we recommend a carbon-tipped, multi-purposed chop saw. As the formed end of the board is lost when cut, these can be placed in less visual areas against a wall or edging profile. Matching Touch-up Coating for exposed ends is available to buy separately. See page 35.

## What fixings should be used to fix Millboard?

Following extensive trials, we recommend and supply Durafix® stainless steel screws, designed specifically for Millboard. There's no need to pre-drill or countersink Millboard and the unique Lastane® material self-heals, leaving a virtually indistinguishable mark on the surface. See pages 35 and 37.

## Can you recommend an installer?

A nationwide network of APPROVED Installers are available at [www.millboard.co.uk](http://www.millboard.co.uk). Chosen for their professionalism and high quality, you should always follow normal precautions before entering into a contract with a third party, especially if a deposit payment is required.

## Something else?

For any other technical, installation or care questions, go to [www.millboard.co.uk](http://www.millboard.co.uk), call our technical team on 024 7643 9943, or email us at [enquiries@millboard.co.uk](mailto:enquiries@millboard.co.uk)

## Order Millboard samples

There's nothing like seeing Millboard for yourself. Simply go to [www.millboard.co.uk](http://www.millboard.co.uk) to find your nearest merchant or display centre.



# After Care

Now that your Millboard is installed, make sure it stays in premium condition with our handy tips on aftercare.

## Factory sealed

Millboards are surface sealed in the factory to ensure they arrive in premium condition. In the first few weeks of use, rainwater will sit on the surface in globules, but don't worry – this is normal and will stop once the temporary surface seal breaks down.

## Marking

The Lastane® finish is highly resistant to scratches and food and drink stains, and everyday wear and tear. Sharp objects such as unprotected table or chair legs, spiked shoes or metal planter bases can leave marks if dragged across the surface, so take care when moving these items around. The risk of marking from strong dyes and stains such as berries and animal droppings will be reduced if removed as soon as possible.

## Winter ice and snow

A small amount of granulated white salt can be used to keep your Millboard ice-free. Please don't use rock salt, as this contains clay and grit and can be abrasive. When winter's over, clean the surface with soapy water and a soft broom.

## Cleaning

Because Millboard is made of non-porous composite, it resists mossy build-up and stains, so needs very little maintenance. To remove spills and marks, simply use a mild detergent and a cloth. Just steer clear of solvents, chemicals and abrasive cleaners that could damage your Millboard – and there's normally no need for pressure washing.





# It's simple to enjoy Millboard



## How to order

1

### Get inspired

Check out our brochure and website for style ideas and the complete Millboard collection.

2

### Choose your Millboard

Order your free samples to help you choose the colour and finish for your project, or visit a display centre or merchant.

3

### Remember the finishing touches

Take a look at our matching fascias and edging, essential fixings and more.

4

### Contact a professional

Arrange an independent fitter or ask us for a recommendation.

Visit our website, [www.millboard.co.uk](http://www.millboard.co.uk) for more details.

5

### Or buy and fit it yourself

You can also order Millboard from an authorised merchant and install it yourself.

Live.  
Life.  
Outside.™

The Millboard Company Ltd  
UK Head Office  
Castle Court  
Bodmin Road  
Coventry CV2 5DB

T 44 (0)24 7643 9943  
F 44 (0)24 7661 1668  
E [enquiries@millboard.co.uk](mailto:enquiries@millboard.co.uk)  
W [millboard.co.uk](http://millboard.co.uk)

Company registered No. 06061318  
VAT No: 980 616602

EVERYBODY'S TALKING  
ABOUT MILLBOARD...

Like it  
Share it  
Pin it  
Tweet it

 MillboardFlooring

 Millboard\_UK

 millboarddeckin

---

© 2015 The Millboard Company Ltd., Millboard®, Lastane®, Durafix®, Lasta-Grip®, Esterno® and the phrase "Live. Life. Outside.™" are protected Trade Marks. Patents and Patents Pending apply to Millboard® products. The company will vigorously defend its patent rights. Due to printing restraints, actual colours may vary from those shown in brochure. This brochure is not to be reproduced or copied without written permission from Millboard directors. Millboard has a policy of continual improvement to specification. Product blend, colours and sizes may change without notice. All sizes and measurements are nominal. Information is correct at time of going to press. Patent Nos include GB 2445714, GB 2449184, USA 8,065,849, CAN 2664329, EU 1951971.



Live.  
Life.  
Outside.™



The Millboard Company Ltd  
UK Head Office  
Castle Court  
Bodmin Road  
Coventry CV2 5DB

T 44 (0)24 7643 9943  
F 44 (0)24 7661 1668  
E [enquiries@millboard.co.uk](mailto:enquiries@millboard.co.uk)  
W [www.millboard.co.uk](http://www.millboard.co.uk)  
Company registered No. 06061318  
VAT No: 980 616602